



General Aptitude (GA)

Q.1 – Q.5 Multiple Choice Question (MCQ), carry ONE mark each (for each wrong answer: – 1/3).

Q.1	(i) Arun and Aparna are here. (ii) Arun and Aparna is here. (iii) Arun's families is here. (iv) Arun's family is here. Which of the above sentences are grammatically CORRECT?
(A)	(i) and (ii)
(B)	(i) and (iv)
(C)	(ii) and (iv)
(D)	(iii) and (iv)

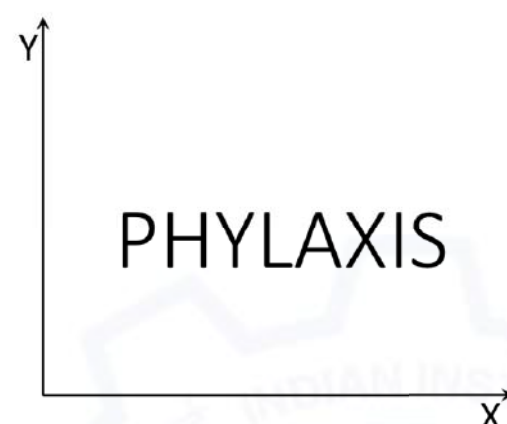

<p>Q.2</p>	 <p>The mirror image of the above text about the X-axis is</p>
<p>(A)</p>	<p>PHYLAXIS</p>
<p>(B)</p>	<p>PHYLAXIS</p>
<p>(C)</p>	<p>PHYLAXIS</p>
<p>(D)</p>	<p>PHYLAXIS</p>



Q.3	Two identical cube shaped dice each with faces numbered 1 to 6 are rolled simultaneously. The probability that an even number is rolled out on each dice is:
(A)	$\frac{1}{36}$
(B)	$\frac{1}{12}$
(C)	$\frac{1}{8}$
(D)	$\frac{1}{4}$

Q.4	<p>\oplus and \odot are two operators on numbers p and q such that $p \odot q = p - q$, and $p \oplus q = p \times q$</p> <p>Then, $(9 \odot (6 \oplus 7)) \odot (7 \oplus (6 \odot 5)) =$</p>
(A)	40
(B)	-26
(C)	-33
(D)	-40



Q.5	Four persons P, Q, R and S are to be seated in a row. R should not be seated at the second position from the left end of the row. The number of distinct seating arrangements possible is:
(A)	6
(B)	9
(C)	18
(D)	24

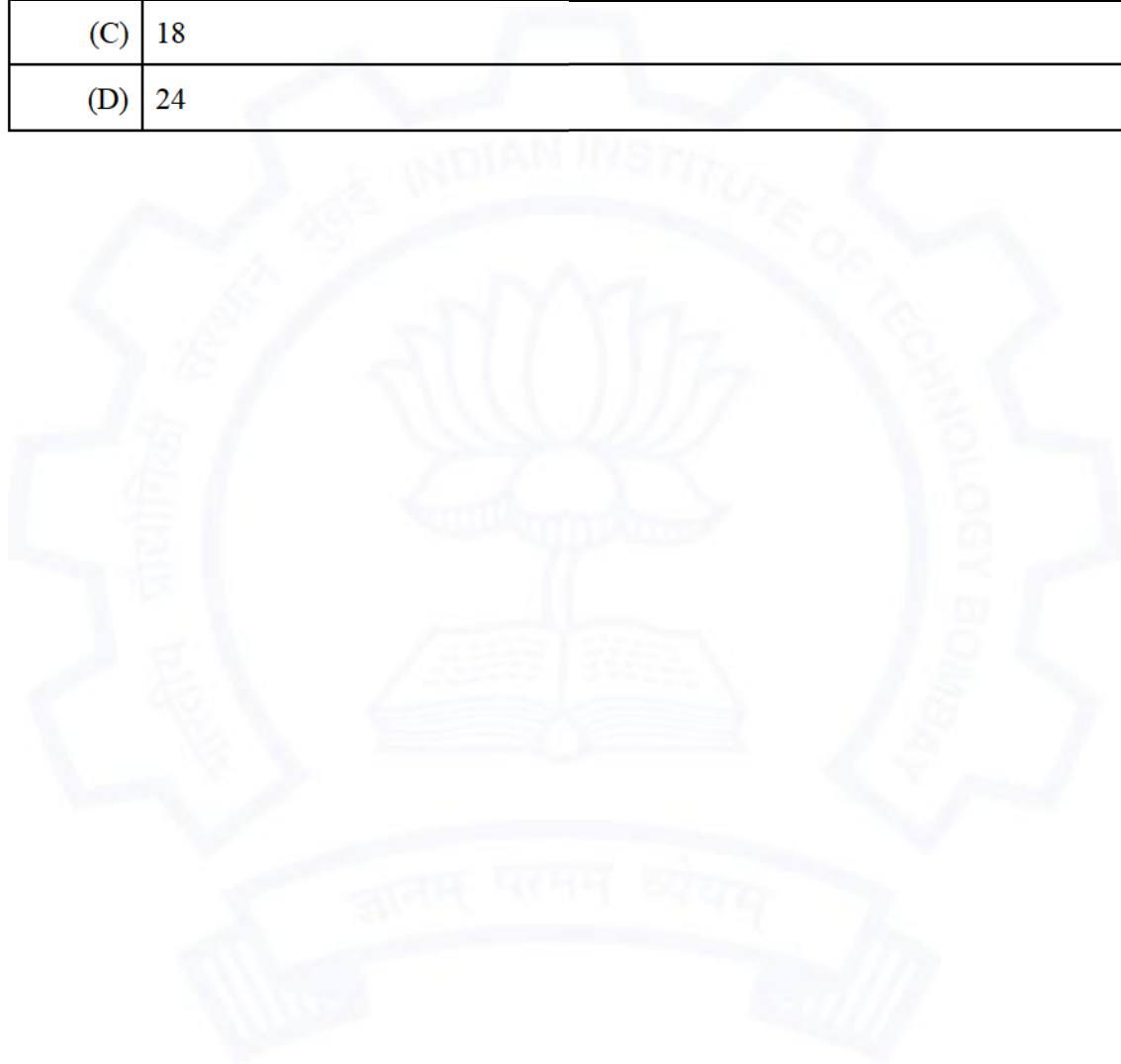



Q. 6 – Q. 10 Multiple Choice Question (MCQ), carry TWO marks each (for each wrong answer: – 2/3).

Q.6	<p>On a planar field, you travelled 3 units East from a point O. Next you travelled 4 units South to arrive at point P. Then you travelled from P in the North-East direction such that you arrive at a point that is 6 units East of point O. Next, you travelled in the North-West direction, so that you arrive at point Q that is 8 units North of point P.</p> <p>The distance of point Q to point O, in the same units, should be _____</p>
(A)	3
(B)	4
(C)	5
(D)	6

Q.7	<p>The author said, “Musicians rehearse before their concerts. Actors rehearse their roles before the opening of a new play. On the other hand, I find it strange that many public speakers think they can just walk on to the stage and start speaking. In my opinion, it is no less important for public speakers to rehearse their talks.”</p> <p>Based on the above passage, which one of the following is TRUE?</p>
(A)	The author is of the opinion that rehearsing is important for musicians, actors and public speakers.
(B)	The author is of the opinion that rehearsing is less important for public speakers than for musicians and actors.
(C)	The author is of the opinion that rehearsing is more important only for musicians than public speakers.
(D)	The author is of the opinion that rehearsal is more important for actors than musicians.



Q.8	1. Some football players play cricket. 2. All cricket players play hockey. Among the options given below, the statement that logically follows from the two statements 1 and 2 above, is:
(A)	No football player plays hockey.
(B)	Some football players play hockey.
(C)	All football players play hockey.
(D)	All hockey players play football.



<p>Q.9</p>	<div style="text-align: center;"> </div> <p>In the figure shown above, PQRS is a square. The shaded portion is formed by the intersection of sectors of circles with radius equal to the side of the square and centers at S and Q.</p> <p>The probability that any point picked randomly within the square falls in the shaded area is _____</p>
<p>(A)</p>	<p>$4 - \frac{\pi}{2}$</p>
<p>(B)</p>	<p>$\frac{1}{2}$</p>
<p>(C)</p>	<p>$\frac{\pi}{2} - 1$</p>
<p>(D)</p>	<p>$\frac{\pi}{4}$</p>

<p>Q.10</p>	<p>In an equilateral triangle PQR, side PQ is divided into four equal parts, side QR is divided into six equal parts and side PR is divided into eight equal parts. The length of each subdivided part in cm is an integer.</p> <p>The minimum area of the triangle PQR possible, in cm², is</p>
<p>(A)</p>	<p>18</p>
<p>(B)</p>	<p>24</p>
<p>(C)</p>	<p>$48\sqrt{3}$</p>
<p>(D)</p>	<p>$144\sqrt{3}$</p>



Mining Engineering (MN)

Q.1 – Q.19 Multiple Choice Question (MCQ), carry ONE mark each (for each wrong answer: – 1/3).

Q.1	Tricone roller bit is used with
(A)	down-the-hole hammer.
(B)	Jack hammer.
(C)	rotary-percussive drill.
(D)	rotary drill.

Q.2	Resuing method of mining is practiced for
(A)	thick vein deposit.
(B)	massive shallow deposit.
(C)	narrow vein deposit.
(D)	massive deep-seated deposit.

Q.3	The equipment used for both drop cut and terrace cut in surface mining is
(A)	surface miner.
(B)	shovel.
(C)	dragline.
(D)	bucket wheel excavator.



Q.4	Surface miner does NOT have a
(A)	differential gear for turning.
(B)	tensioning arrangement for crawler.
(C)	scraper plate behind the drum.
(D)	pick cooling system.

Q.5	Induced blasting enhances production in
(A)	sublevel stoping.
(B)	block caving.
(C)	cut and fill mining.
(D)	shrinkage stoping.

Q.6	The measures of dispersion of a dataset are
(A)	standard deviation, range and mode.
(B)	standard deviation, range and interquartile range.
(C)	variance, range and median.
(D)	interquartile range, median and mode.

Q.7	NONEL is used as down-the-hole initiator to
(A)	avoid generation of air overpressure.
(B)	provide precise delay.
(C)	avoid deflagration of column charge.
(D)	reduce ground vibration.

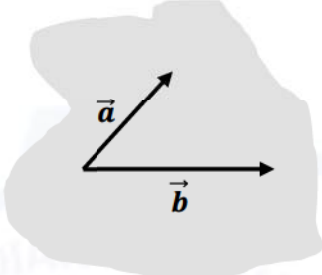

<p>Q.8</p>	<p>The vectors \vec{a} and \vec{b} act in a plane as shown below. The magnitude of the vector $\vec{c} = (\vec{a} + \vec{b}) \times (\vec{a} - \vec{b})$ is</p> 
<p>(A)</p>	<p>zero.</p>
<p>(B)</p>	<p>half to the area bounded by the vectors \vec{a} and \vec{b}.</p>
<p>(C)</p>	<p>equal to the area bounded by the vectors \vec{a} and \vec{b}.</p>
<p>(D)</p>	<p>twice the area bounded by the vectors \vec{a} and \vec{b}.</p>

<p>Q.9</p>	<p>As per MMDR Act 1957, for the allocation of lease of minor minerals</p>
<p>(A)</p>	<p>the State Government is authorised to give the permit.</p>
<p>(B)</p>	<p>the Central Government is authorised to give the permit.</p>
<p>(C)</p>	<p>the State Government is authorised to give permit but with the consent of Central Government.</p>
<p>(D)</p>	<p>the Central Government is authorised to give permit but with the consent of State Government.</p>

<p>Q.10</p>	<p>In photogrammetry, the ‘Tilt of a photograph’ refers to the angle between the</p>
<p>(A)</p>	<p>lines joining the opposite fiducial marks of a photograph.</p>
<p>(B)</p>	<p>normal to the plane of photograph and optical axis.</p>
<p>(C)</p>	<p>vertical and the axis of the flight.</p>
<p>(D)</p>	<p>vertical and optical axis of the camera.</p>



Q.11	The hydraulic sand stowing pipeline layout should be such that
(A)	the geometric profile must coincide with the hydraulic gradient line.
(B)	the hydraulic profile should always be below the hydraulic gradient line.
(C)	the hydraulic profile should always be above the hydraulic gradient line.
(D)	the geometric profile should always be above the hydraulic gradient line.

Q.12	For a “positive definite” square matrix, the TRUE statement is
(A)	the matrix is singular.
(B)	all the eigen values of the matrix are greater than zero.
(C)	all the eigen values of the matrix are zero.
(D)	some of the eigen values can be less than zero.

Q.13	The standard normal distribution is a
(A)	non-parametric distribution.
(B)	single parameter distribution.
(C)	two-parameter distribution.
(D)	three-parameter distribution.

Q.14	Variance of the sum of two statistically independent random variables X and Y, σ_{X+Y}^2, is
(A)	$\sigma_X^2 + \sigma_Y^2$.
(B)	$\sigma_X^2 + \sigma_Y^2 + 2\sigma_{XY}$.
(C)	$\sigma_X^2 + \sigma_Y^2 + \sigma_{XY}$.
(D)	$\sigma_X^2 + \sigma_Y^2 - 2\sigma_{XY}$.



Q.15	The difference between depreciation and amortization allowances in tax calculation is that
(A)	depreciation is for a tangible asset applicable on its declared life; whereas amortization is for an intangible asset applicable on a specified period.
(B)	depreciation is for an intangible asset applicable on its declared life; whereas amortization is for a tangible asset applicable on a specified period.
(C)	depreciation is for a tangible asset applicable on a specified period; whereas amortization is for an intangible asset applicable on its declared life.
(D)	depreciation is for an intangible asset applicable on a specified period; whereas amortization is for a tangible asset applicable on its declared life.

Q.16	Owning cost of a machine does NOT include
(A)	purchase price.
(B)	insurance.
(C)	interest.
(D)	operating cost.

Q.17	Folds are the structural features resulting from
(A)	ductile deformation of earth crust.
(B)	brittle deformation of earth crust.
(C)	high impact tectonic stresses of earth crust.
(D)	fracturing of earth crust.



<p>Q.18</p>	<p>The CORRECT curve showing the relationship between vertical stress on a coal pillar and extraction ratio of a bord and pillar panel in a horizontal seam is</p> <div data-bbox="641 443 1117 779" data-label="Figure"> </div>
<p>(A)</p>	<p>Curve A.</p>
<p>(B)</p>	<p>Curve B.</p>
<p>(C)</p>	<p>Curve C.</p>
<p>(D)</p>	<p>Curve D.</p>

<p>Q.19</p>	<p>Given impeller diameter D, speed of rotation n and air density ρ, for geometrically similar fans, the fan pressure is proportional to</p>
<p>(A)</p>	<p>$nD^2\rho$.</p>
<p>(B)</p>	<p>$n^2D^2\rho$.</p>
<p>(C)</p>	<p>$n^2D^5\rho^2$.</p>
<p>(D)</p>	<p>$n^3D^5\rho$.</p>



Q.20 – Q.25 Numerical Answer Type (NAT), carry ONE mark each (no negative marks).

Q.20	A coal sample having moisture content of 8.0% has unit weight 15.6 kN/m ³ . The dry unit weight of the sample, in kN/m ³ is _____. <i>[round off to 2 decimal places]</i>
-------------	--

Q.21	The value of the integral $I = \int_0^4 \sqrt{x} dx$ computed using Simpson's 1/3 rule with 2 subintervals is _____. <i>[round off to 3 decimal places]</i>
-------------	--

Q.22	In the context of sound frequency analysis, the lower and upper frequencies of a 1/1 octave band are 710 Hz and 1420 Hz respectively. The corresponding centre frequency of the band in Hz, is _____. <i>[round off to the nearest integer]</i>
-------------	---

Q.23	In Battle Environmental Evaluation System (BEES) of Environmental Impact Assessment (EIA), "air pollution" has a Parameter Importance Unit (PIU) value of 52. The Environmental Quality (EQ) score of a project with respect to air pollution was 0.8 before the project implementation and it becomes 0.6 after the project implementation. The difference in the "Environmental Impact Unit (EIU)", before and after the project implementation is _____. <i>[round off to 2 decimal places]</i>
-------------	---

Q.24	A system consists of four components connected functionally in a parallel configuration. The reliability of the individual components is 0.40, 0.60, 0.50 and 0.40. The system reliability, is _____. <i>[round off to 3 decimal places]</i>
-------------	--

Q.25	A vehicle is moving at a speed of 12 m/s on a level road. It applies emergency brakes and starts to skid without rolling in a straight path. The deceleration of the vehicle is constant after braking and it comes to rest at a distance of 15 m. Assuming, $g = 10 \text{ m/s}^2$, the coefficient of kinetic friction between the tyres and road is _____. <i>[round off to 2 decimal places]</i>
-------------	---



Q.26 – Q.36 Multiple Choice Question (MCQ), carry TWO mark each (for each wrong answer: – 2/3).

Q.26	In a bord and pillar panel six shuttle cars, each of 10 tonne capacity, are deployed to transport coal produced by two continuous miners to a belt conveyor. Each shuttle car on an average carries 80% of its rated capacity and makes 7 round trips in an hour. The belt conveyor has a capacity such that the effective material cross section area is of 0.09 m ² and runs at a speed 1.1 m/s. The broken coal has a bulk density of 1.2 tonne/m ³ . The ratio between the production and the capacity of the belt conveyor, in percent is
(A)	65.46
(B)	71.42
(C)	78.56
(D)	82.46

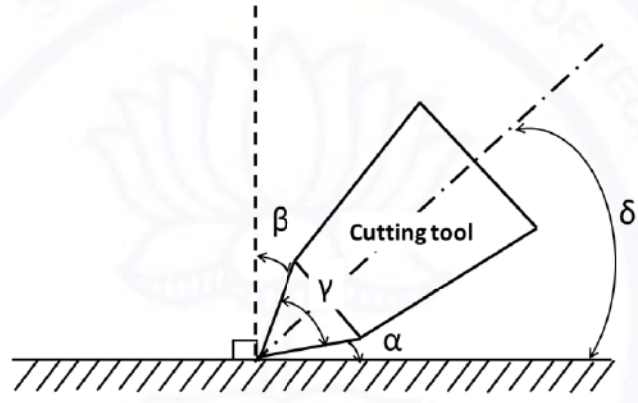

<p>Q.27</p>	<p>With reference to the figure related to rock cutting by point attack tool, match the angle with corresponding name.</p> <table border="1" data-bbox="568 420 1144 745"> <thead> <tr> <th>Angle</th> <th>Name</th> </tr> </thead> <tbody> <tr> <td>P. α</td> <td>1. Cutting angle</td> </tr> <tr> <td>Q. β</td> <td>2. Clearance angle</td> </tr> <tr> <td>R. δ</td> <td>3. Wedge angle</td> </tr> <tr> <td>S. γ</td> <td>4. Rake angle</td> </tr> </tbody> </table> 	Angle	Name	P. α	1. Cutting angle	Q. β	2. Clearance angle	R. δ	3. Wedge angle	S. γ	4. Rake angle
Angle	Name										
P. α	1. Cutting angle										
Q. β	2. Clearance angle										
R. δ	3. Wedge angle										
S. γ	4. Rake angle										
(A)	P-2, Q-4, R-1, S-3.										
(B)	P-4, Q-2, R-1, S-3.										
(C)	P-2, Q-4, R-3, S-1.										
(D)	P-4, Q-2, R-3, S-1.										

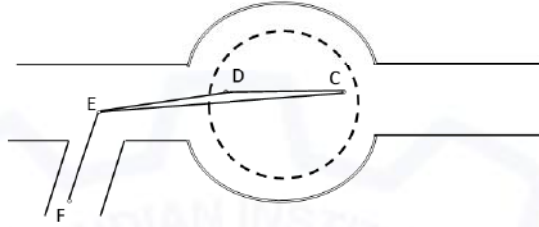

<p>Q.28</p>	<p>The pit bottom in a correlation survey is shown in the figure. Points C and D represent two suspended wires. The bearing of line CD is $286^{\circ}00'00''$ and its length is 4.64 m. The angle CED is measured as $00^{\circ}00'40''$. The length of line DE is 5.46 m. Considering the Weisbach triangle method, the bearing of the line CE is</p> 
<p>(A)</p>	<p>$286^{\circ}00'47''$</p>
<p>(B)</p>	<p>$285^{\circ}59'12.9''$</p>
<p>(C)</p>	<p>$286^{\circ}00'40''$</p>
<p>(D)</p>	<p>$285^{\circ}00'47.1''$</p>

<p>Q.29</p>	<p>A dump truck moves up an incline of 5° with constant tractive force of 800 kN. The gross mass of the truck is 250 tonne and its rolling resistance is 545 kN. The acceleration due to gravity is $10 \text{ m}^2/\text{s}$. The time required, in s, to reach a speed of 3.3 m/s from 1.0 m/s is</p>
<p>(A)</p>	<p>22.0</p>
<p>(B)</p>	<p>15.5</p>
<p>(C)</p>	<p>3.3</p>
<p>(D)</p>	<p>0.2</p>



Q.30	In a longwall panel, face is supported with shields of yield capacity 460 tonne per shield. The distance from the canopy tip to coal face is 0.15 m when the support is fully advanced. The depth of web is 0.60 m. The shields are set skin to skin at the face. Length of the canopy of the shield is 3.25 m and width 1.5 m. Setting capacity is 80% of the yield capacity. The setting resistance at the maximum and minimum span of the coal face, in tonne/m², respectively are
(A)	61.33 and 72.15.
(B)	63.72 and 75.48.
(C)	76.66 and 90.19.
(D)	91.99 and 108.22.

Q.31	A 10 ml sample of wastewater is diluted with water having no BOD, to fill a 300 ml BOD bottle. The initial DO of the diluted waste water is 9.0 mg/l. If the BOD₅ of the waste water sample is 60 mg/l, the final DO of the diluted waste water in mg/l, is
(A)	5.0
(B)	6.0
(C)	7.0
(D)	8.0

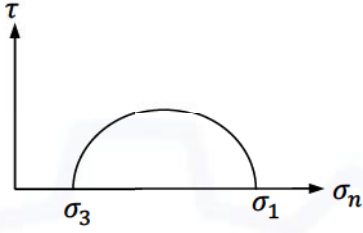
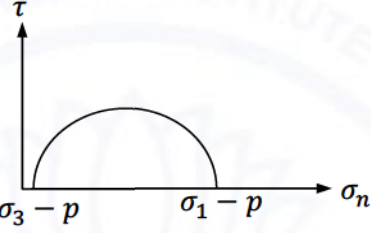
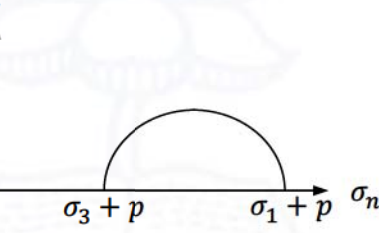
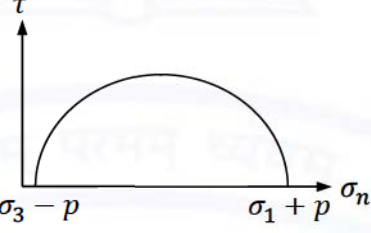
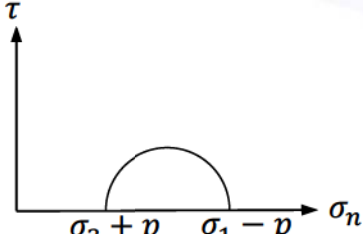

<p>Q.32</p>	<p>The Mohr circle of stress of a dry porous rock is shown in the figure. If the rock is fully saturated with a pore pressure p, then the Mohr circle takes the form of</p> 
<p>(A)</p>	
<p>(B)</p>	
<p>(C)</p>	
<p>(D)</p>	



Q.33 The straight line shown depicts the failure criterion of a rock type. The values of stress at points A and B are as shown. The safety factor at the points A and B respectively are

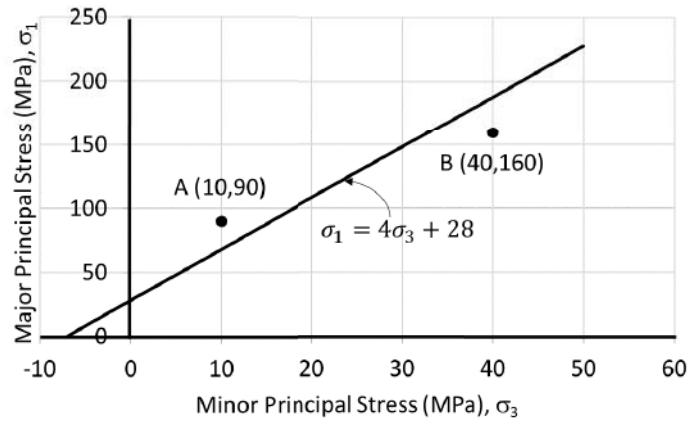

(A) 1.175 and 0.755

(B) 1.324 and 0.851

(C) 0.851 and 1.324

(D) 0.755 and 1.175



Q.34 Figure shown relates to the manufacture of roof bolts. With respect to the cost/revenue vs production level, match the appropriate trend line with corresponding description.

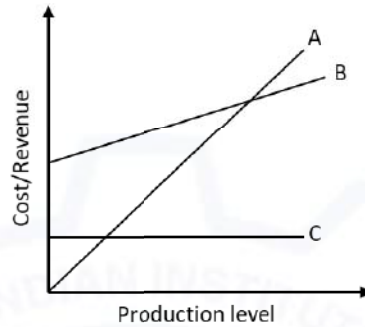

Line	Item
(P). A	(1). Total cost
(R). B	(2). Indirect operating cost
(S). C	(3). Revenue

(A) (P)-(1); (R)-(3); (S)-(2).

(B) (P)-(2); (R)-(1); (S)-(3).

(C) (P)-(1); (R)-(2), (S)-(3).

(D) (P)-(3); (R)-(1); (S)-(2).

Q.35	The value of $\lim_{x \rightarrow \infty} (x\sqrt{x^2 + b^2} - \sqrt{x^4 + b^4})$ is
(A)	0.
(B)	$\frac{b^2}{2}$.
(C)	∞ .
(D)	b^2 .



Q.36	In order to check whether iron ore is supplied to the specification of 62% Fe, a steel company has conducted a hypothesis test with the null hypothesis as $H_0: \mu_{Fe} = 62\%$ and alternative hypothesis $H_a: \mu_{Fe} < 62\%$. A random sample of 5 observations reveal the following grade values of the lot, 58%, 56%, 60%, 64%, 62%. The t-test statistic for the hypothesis is
(A)	- 3.000
(B)	1.414
(C)	- 1.414
(D)	3.000



Q.37 – Q.55 Numerical Answer Type (NAT), carry TWO mark each (no negative marks)

Q.37 Production planning of a small quarry having 3 years of life is shown in the figure. The following information of revenue and cost data are available.

Ore: 3.0 million tonne Ore: 3.0 million tonne Ore: 3.0 million tonne

3rd Year 2nd Year 1st Year

Waste: 5.0 million m³ Waste: 5.5 million m³ Waste: 5.0 million m³

Selling price of ore = Rs. 1500/tonne
 Ore mining cost = Rs. 500/tonne
 Waste mining cost = Rs. 500/m³
 Initial capital = Rs. 1000 million
 Discount rate = 10 %

By neglecting depreciation, salvage value and corporate tax, the NPV of the mining project, in million Rs., is _____. [round off to 2 decimal places]

Q.38 A triangular distributed load is applied on top of a beam as shown in the figure. The value of maximum bending moment in kN-m is _____. [round off to 2 decimal places]

5 kN/m

A B

2 m

Q.39 For a dumpy level, the bubble tube has sensitivity of 40" for one division. While taking a staff reading at a distance of 60 m, the bubble is out of centre by 2 divisions. The error in staff reading in mm is _____. [round off to one decimal place]



Q.40	<p>On an old plan of scale 1:1000, leasehold area of a mine is now measured as 802 cm² using a planimeter. The plan is found to have shrunk, such that the original line of 10 cm is now measured as 9.8 cm on the plan. True lease hold mine area, in m², is _____. [<i>round off to the nearest integer</i>]</p>
Q.41	<p>CO is released from a point source on a level ground at a rate of 25 g/s. The average wind speed is 5 m/s. The dispersion coefficients are 150 m and 200 m in horizontal and vertical directions, respectively, at a receiver station located on the ground along the downwind direction. Assuming the plume follows Gaussian dispersion model, the concentration of CO, in µg/m³, at the station is _____. [<i>round off to 2 decimal places</i>]</p>
Q.42	<p>Assume that COVID-19 growth rate of number of infections per day (c) in a certain population is represented by the following differential equation.</p> $100 \frac{dc}{dt} - 7c = 0$ <p>Where, t stands for time in days. Time taken for the number of infections per day to double, in days, is _____. [<i>round off to the nearest integer</i>]</p>
Q.43	<p>Ore is hoisted from 620 m depth using a single skip of 7 tonne pay load. The skip winding system has constant acceleration/deceleration of 1 m/s² and a constant speed of 10 m/s. The skip loading time and unloading time are 120 s and 60 s, respectively. Considering the overall utilization of the skip as 70 %, the maximum daily capacity of the winding system, in tonne, is _____. [<i>round off to the nearest integer</i>]</p>
Q.44	<p>In an analysis of fragmented blast muck, the mean fragment size is found to be 60 cm with uniformity index of 1.25. Considering Rosin-Ramler equation, the cumulative mass fraction, in percent, to pass the grizzly screen size of 100 cm is _____. [<i>round off to 2 decimal places</i>]</p>



Q.45 A single-acting reciprocating ram pump, while running at 120 rpm, delivers water at a rate of 10 litres per second. Considering the ram diameter is 150 mm and stroke length is 300 mm, the volumetric efficiency of the pump, in percent is _____.
[round off to one decimal place]

Q.46 In a sand stowing arrangement, the slurry has a sand concentration of 35% by volume. The specific gravity of sand grain is 2.6. The concentration of sand by weight, in percent, in the slurry is _____. [round off to one decimal place]

Q.47 In a surface mine, third bench from the pit bottom is blasted, as shown in the figure. The width, height and slope angle of each bench are 8 m, 6 m, and 80°, respectively. A fly rock is projected at an angle of 45° with the horizontal with initial velocity, v. If the acceleration due to gravity is 10 m/s² then the minimum velocity (v) in m/s required for the fly rock to reach just beyond toe of the pit slope is _____.
[round off to 2 decimal places]

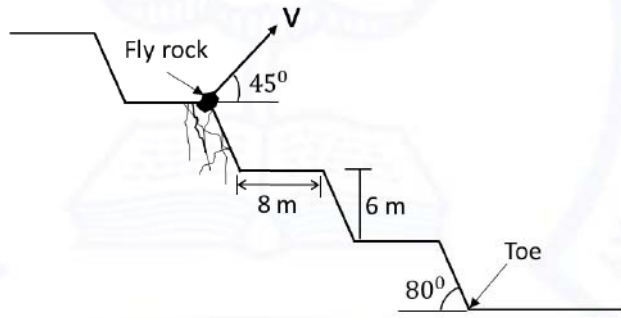

Q.48 Injury experience is studied in an underground coal mine with a random sample of 132 workers. The results of the study are tabulated below.

	Injured	Non-injured	Total workers
Roof-bolter operators	13	12	25
Loader operators	35	72	107
Total workers	48	84	132

The odds ratio of experiencing an injury by the roof-bolter operators when compared to the loader operators is _____. [round off to 2 decimal places]



Q.49 A random variable X is defined by

$$X = \begin{cases} -2 & \text{probability } 1/3 \\ 3 & \text{probability } 1/2 \\ 1 & \text{probability } 1/6 \end{cases}$$

The value of $E(X^2)$ is _____. [round off to one decimal place]

Q.50 A project network consists of the following activities

Activity	Immediate predecessors	Duration (days)
A	--	3
B	--	4
C	A, B	5
D	B	6
E	D	7
F	C, E	8
G	D	9
H	F, G	X

If the project completion time is 30 days, then the value of 'X', in days, is _____.
[in integer]

Q.51 Rate of fuel consumption f_c (litres per hour) of a truck varies with truck speed x , (kmph) as given below

$$f_c = 20 + \frac{x^2}{50}$$

The fuel price is Rs. 70 per litre. Other costs amount to Rs. 500 per hour. If the truck travels 100 km from a coal mine to a thermal plant, the speed of the truck, in kmph, that minimizes the total cost is _____. [round off to one decimal place]



Q.52 A cement company has three factories which transport cement to four distribution centres. The daily production of each factory, the demand at each distribution centre, and the associated transportation cost per tonne from factory to distribution centre are given in the Table.

		Distribution centre				Supply (tonnes/day)
		D ₁	D ₂	D ₃	D ₄	
Factory	F ₁	20	30	110	70	600
	F ₂	10	0	60	10	100
	F ₃	50	80	150	90	1000
	Demand (tonnes/day)	700	500	300	200	

The initial basic feasible solution using the least-cost rule is _____. [in integer]

Q.53 The grade-tonnage distribution for the ultimate pit of a mine is given below.

Cu grade (%)	Cumulative million tonnes below the grade
0.1	0
0.4	15.0
0.5	17.0
0.6	18.0
0.7	19.0
0.9 and above	23.0

The mill cut-off grade is 0.5 % Cu. The annual mining capacity (ore + waste) is 4.5 million tonne and milling capacity is 1.0 million tonne. Excavation is planned in such a way that either of the mine or the mill runs at full capacity throughout. The planned life of the mine, in years, is_____.

[round off to one decimal place]



Q.54 A coal mine operating in three shifts produces 400 tonnes of coal per day with a face OMS of 1.0 from panel A, and 200 tonnes of coal with face OMS of 1.0 from panel B. The panel A and panel B are in parallel with resistance $0.6 \text{ N s}^{-2} \text{ m}^{-8}$ and $0.5 \text{ N s}^{-2} \text{ m}^{-8}$, respectively. If the panels are supplied with minimum permissible quantity as per CMR 2018, the requisite regulator resistance to meet the conditions in $\text{N s}^{-2} \text{ m}^{-8}$ is _____. [round off to 2 decimal places]

Q.55 A set of three steel bars of equal cross-sectional area of 0.01 m^2 are loaded, as shown in the figure. The elastic modulus of steel is 200 GPa. The overall change of length of the complete set of bars, in mm, is _____. [round off to 3 decimal places]

END OF THE QUESTION PAPER

Graduate Aptitude Test in Engineering (GATE 2021)

Answer Keys and Marks for Subject/Paper: Mining Engineering (MN)

Q. No.	Session	Question Type MCQ/MSQ/NAT	Section Name	Answer Key/Range	Marks	Negative Marks
1	2	MCQ	GA	B	1	1/3
2	2	MCQ	GA	B	1	1/3
3	2	MCQ	GA	D	1	1/3
4	2	MCQ	GA	D	1	1/3
5	2	MCQ	GA	C	1	1/3
6	2	MCQ	GA	C	2	2/3
7	2	MCQ	GA	A	2	2/3
8	2	MCQ	GA	B	2	2/3
9	2	MCQ	GA	C	2	2/3
10	2	MCQ	GA	D	2	2/3
1	2	MCQ	MN	D	1	1/3
2	2	MCQ	MN	C	1	1/3
3	2	MCQ	MN	D	1	1/3
4	2	MCQ	MN	A	1	1/3
5	2	MCQ	MN	B	1	1/3
6	2	MCQ	MN	B	1	1/3
7	2	MCQ	MN	C	1	1/3
8	2	MCQ	MN	D	1	1/3
9	2	MCQ	MN	A	1	1/3
10	2	MCQ	MN	D	1	1/3

GATE 2021 Answer Key for Mining Engineering (MN)

Q. No.	Session	Question Type MCQ/MSQ/NAT	Section Name	Answer Key/Range	Marks	Negative Marks
11	2	MCQ	MN	B	1	1/3
12	2	MCQ	MN	B	1	1/3
13	2	MCQ	MN	C	1	1/3
14	2	MCQ	MN	A	1	1/3
15	2	MCQ	MN	A	1	1/3
16	2	MCQ	MN	D	1	1/3
17	2	MCQ	MN	A	1	1/3
18	2	MCQ	MN	C	1	1/3
19	2	MCQ	MN	B	1	1/3
20	2	NAT	MN	14.00 to 15.00	1	0
21	2	NAT	MN	5.000 to 5.200	1	0
22	2	NAT	MN	999 to 1005	1	0
23	2	NAT	MN	10.40 to 10.40	1	0
24	2	NAT	MN	0.918 to 0.938	1	0
25	2	NAT	MN	0.45 to 0.50	1	0
26	2	MCQ	MN	C	2	2/3
27	2	MCQ	MN	A	2	2/3
28	2	MCQ	MN	B	2	2/3
29	2	MCQ	MN	B	2	2/3
30	2	MCQ	MN	A	2	2/3
31	2	MCQ	MN	C	2	2/3
32	2	MCQ	MN	A	2	2/3
33	2	MCQ	MN	D	2	2/3

GATE 2021 Answer Key for Mining Engineering (MN)

Q. No.	Session	Question Type MCQ/MSQ/NAT	Section Name	Answer Key/Range	Marks	Negative Marks
34	2	MCQ	MN	D	2	2/3
35	2	MCQ	MN	B	2	2/3
36	2	MCQ	MN	C	2	2/3
37	2	NAT	MN	35.50 to 38.30	2	0
38	2	NAT	MN	1.20 to 1.35	2	0
39	2	NAT	MN	22.5 to 24.0	2	0
40	2	NAT	MN	83450 to 83550	2	0
41	2	NAT	MN	50.00 to 55.00	2	0
42	2	NAT	MN	9 to 11	2	0
43	2	NAT	MN	1250 to 1350	2	0
44	2	NAT	MN	71.00 to 75.00	2	0
45	2	NAT	MN	92.0 to 96.0	2	0
46	2	NAT	MN	57.00 to 59.80	2	0
47	2	NAT	MN	9.00 to 11.00	2	0
48	2	NAT	MN	2.20 to 2.30	2	0
49	2	NAT	MN	6.0 to 6.0	2	0
50	2	NAT	MN	5 to 5	2	0
51	2	NAT	MN	35.0 to 38.0	2	0
52	2	NAT	MN	112000 to 112000	2	0
53	2	NAT	MN	6.0 to 6.0	2	0
54	2	NAT	MN	1.80 to 2.00	2	0
55	2	NAT	MN	0.045 to 0.055	2	0